



# Toyota Pocket Style® Fender Flares Set of 4

Set Part #31920-02  
Rev-12 07/18/2017

## STEP 1 – PRIOR TO INSTALLATION

- A) Bushwacker only approves installing the flares according to these written instructions with the hardware provided. WARNING: Failure to install according to these instructions will invalidate the warranty. This includes, but is not limited to using alternative installation methods, hardware, or materials. DO NOT USE: Loctite, SuperGlue, or similar products on the hardware or the flares.**
- B) Fit:** Verify the fit of the flares to vehicle. (Some filing, sanding, or cutting may be necessary to ensure proper fit).
- C) Painting:** (Optional) if paint is desired it must be done prior to installing flares on vehicle. Clean outer surface with a good grade degreaser. DO NOT USE LACQUER THINNER OR ENAMEL REDUCER AS A DEGREASER. Wipe outer surface thoroughly with a tack rag prior to paint. Application of plastic adhesion promoter for ABS plastic as per your paint system manufacturer's recommendations is required. Paint flares using a high quality enamel, or polyurethane automotive paint. If painting edge trim (not recommended), use a flex additive.
- D) Performance:** Using larger Tires may increase the area required to turn the vehicle. Some Tire/Rim combinations may require lowering bump stops and or installing steering stops to prevent tire from contacting flare.
- E) Exhaust System:** Modifications may be necessary to maintain a minimum 4" clearance between flares and exhaust pipes. (Exhaust gases should not vent directly onto flares)
- F) Metal Protection:** All exposed fasteners and bare metal should be treated with rust resistant paint BEFORE installing flares. Spray inner fender wells with undercoating AFTER flare attachments have been completed.
- G) Decals:** Flares may interfere with existing decals on vehicle. If you wish, remove decals prior to installation of flares.
- H) Care & Cleaning:** Bushwacker fender flares are built to last; any detergent you use to wash your vehicle is sufficient to clean the flare. Do not use any harsh abrasive detergents.

## TOOLS FOR EASY INSTALLATION:















- Utility Knife
- Electric Drill
- 5/16" Drill Bit
- Vise Grips
- Trim Tool or Flat Head Screwdriver
- Socket Wrench
- 10mm Socket
- 8mm Socket
- 3/8" Wrench
- 7/16" Wrench
- #2 Phillips Bit
- Grease Pencil

**PLEASE READ:** Dirt and debris can become lodged between the fender flares and the vehicle's fenders, causing scratching and paint wear from vibration. Lund International is not responsible for any damage, and the installation of our fender flares is done with the buyer's understanding that this scratching and paint wear may occur.

## LIMITED LIFETIME WARRANTY AGAINST ANY MANUFACTURING DEFECTS

- To claim a warranty, you must provide Proof of Purchase.

## Included in Hardware Kit:

- |   |  |   |   |  |  |  |
|---|--|---|---|--|--|--|
| 1. <br>CL1-0005,<br>Dacromet "S"<br>Spring Clip,<br>8 pcs      | 2. <br>SW1-0050,<br>10 x 5/16 Phillips<br>Truss Screw,<br>8 pcs | 3. <br>MT1-0002,<br>1" x1" x.017"<br>Black Tab,<br>8 pcs               | 4. <br>SP1-0005,<br>1/2" x .257" x 1"<br>Nylon Spacer,<br>2 pcs      | 5. <br>SP1-0008,<br>1/2" x .260" x 3/4"<br>Spacer,<br>2 pcs    | 6. <br>SP1-0003,<br>1/2" x .260" x 1/4"<br>Nylon Spacer,<br>2 pcs | 7. <br>SP1-0011,<br>1/4" x 5/8" x .187"<br>Neo Black Spacer,<br>4 pcs |
| 8. <br>NU1-0011,<br>1/4-20 SS Serrated<br>Flange Nut,<br>4 pcs | 9. <br>SW1-0005,<br>1/4-20 x 3/4"<br>HxHd Slot Screw,<br>4 pcs  | 10. <br>SW1-0034,<br>14 x 1-3/4" Phillips<br>Truss Tap Screw,<br>4 pcs | 11. <br>SW1-0036,<br>M6-.3 x 20mm Hex<br>Magni Black Screw,<br>2 pcs | 12. <br>SW1-0040,<br>M5-.8 x 35mm<br>SS Bttnhd Screw,<br>6 pcs | 13. <br>WA1-0017,<br>1/4 x 1-1/4" Black<br>Fender Washer<br>6 pcs | 14. <br>WA1-0005,<br>5/16" SAE Zinc<br>Flat Washer,<br>4 pcs          |

# Hardware Kit Continued:

15.



SW1-0032,  
M5-.8 x 9.5mm  
SS Bolt Head Screw,  
38 pcs

16.



WA1-0007,  
.203x.625x.04  
#10 SS Washer,  
42 pcs

17.



NU1-0010,  
M5 x.8 Serrated  
Flange Hex Nut,  
44 pcs

18.



SW1-0022,  
T-30 Torx Bit,  
1 pc

19.



ET1-0002,  
Edge Trim Tool,  
1 pc

20.



GP1-0005,  
Large Wiper Style  
Edge Trim,  
324 inches

## STEP 2 - EDGE TRIM INSTALLATION

A. Peel two to three inches of red vinyl backing away from Edge Trim (GP1-0005) tape. Applying the adhesive side of the edge trim to the inner side of the flare, affix the edge trim to the top edge of the flare (the portion that comes in contact with the vehicle).

B. Press edge trim into place along the top edge of the flare in one-foot increments, pulling red vinyl backing free as you continue to work your way around the top edge of the flare.

C. Apply Edge Trim to Front Bumper Piece if installing.

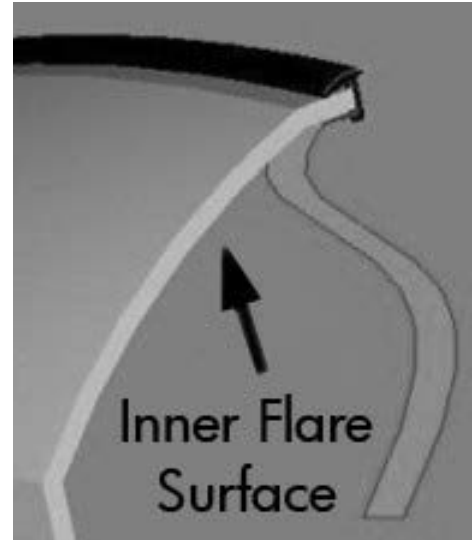

## Front & Rear Flare Pocket Hardware Installation:

*NOTE: Pocket hardware for the Front Bumper Piece is covered later in this instruction set.*



Put a Washer (WA1-0007) on each Bolt (SW1-0032).



**FRONT MAIN & REAR FLARE ONLY:** Put each Bolt/Washer combination through a pocket hole in the flare, Bolt head and Washer on the outside. See Steps 36 - 38 for installation with an Aftermarket Bumper.



**FRONT MAIN & REAR FLARE ONLY:** Place a Nut (NU1-0010) over the end of each Bolt and tighten, using a 1/2" wrench for the Nut and the supplied Torx Bit (SW1-0022) for the Bolt. Repeat for remaining pockets.

## Front Flare & Bumper Piece Installation Procedures: (Driver's Side, No Aftermarket Bumper)

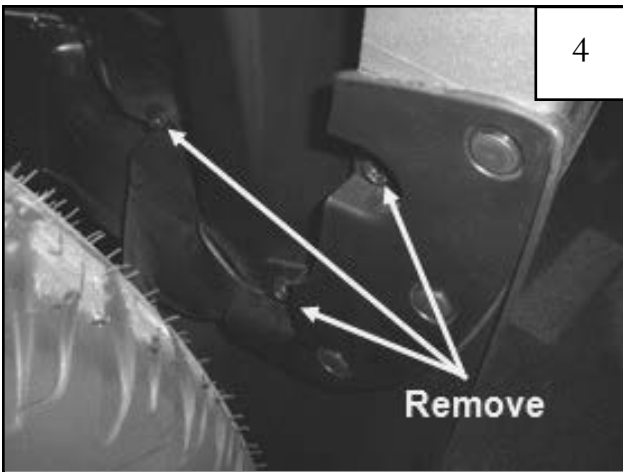

Remove three factory screws from the mud flap. Save screws for reinstallation.

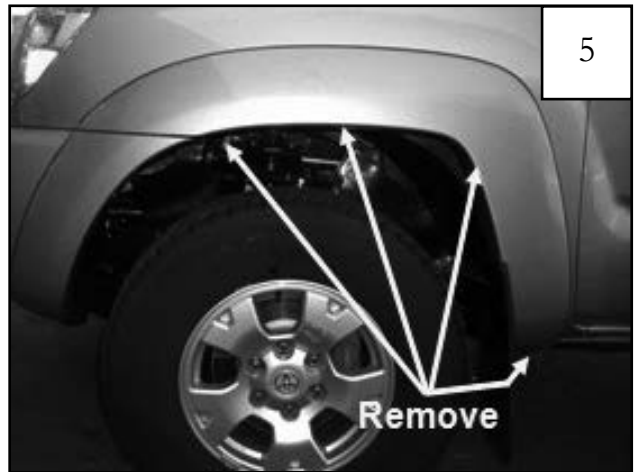

Remove four factory screws from the fender lip. Save screws for reinstallation. Remove flare by pulling part away from side of vehicle.

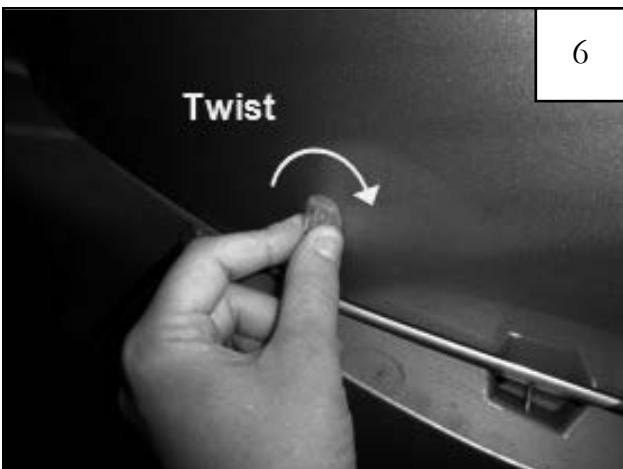

Using a clockwise twisting motion, remove eight factory plastic clips from fender. See step 8.

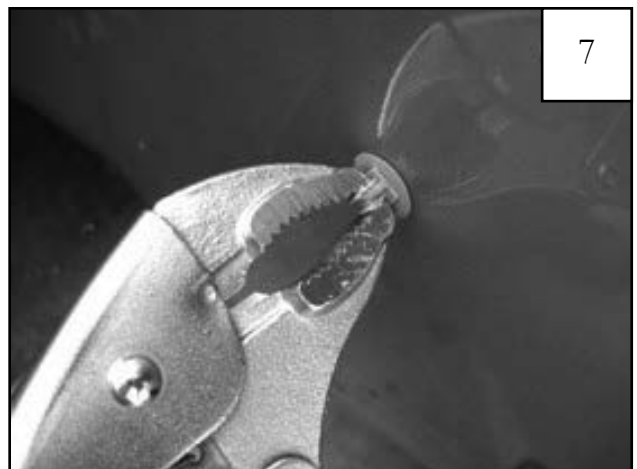

Remove one clip from front using vise grips, pulling with a rocking motion. See step 8.

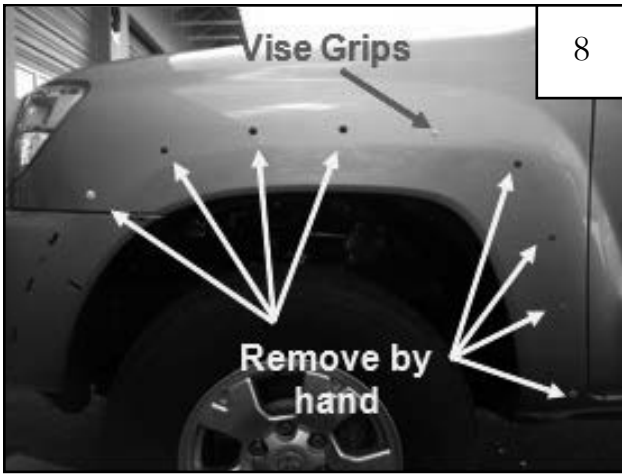

Clip locations.

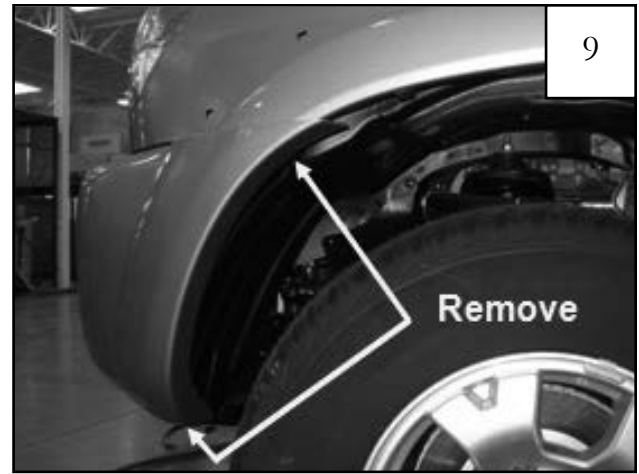

Remove two factory screws from front bumper fender extension. Save screws for reinstallation.

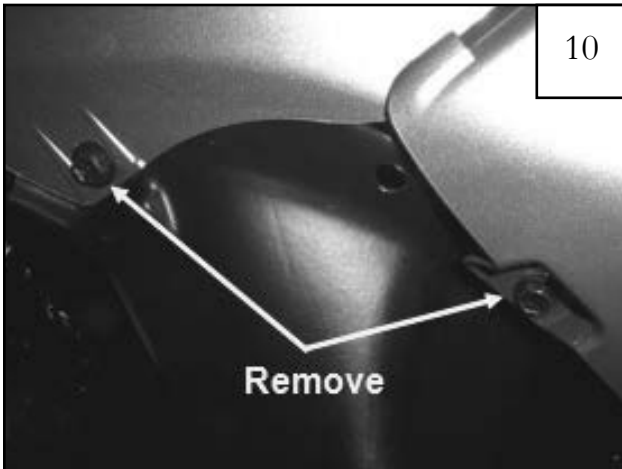

Remove two factory screws underneath the bumper cover.



Pull down bumper cover and splash shield.

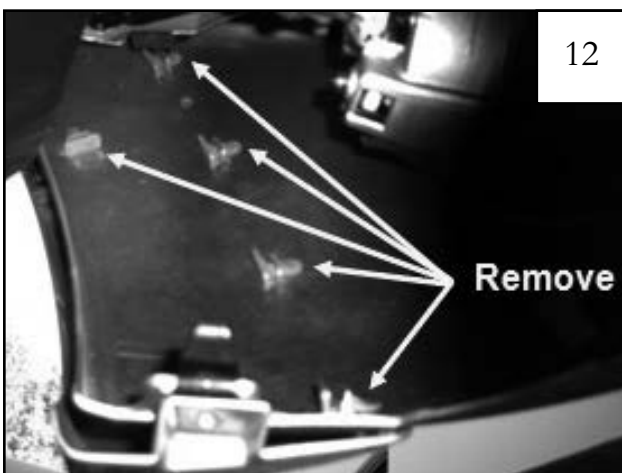

Using a flat head screwdriver, with a pressing motion, remove five plastic clips located inside of bumper cover. Remove front bumper extension.



Remove plastic screw located at front of wheel well by turning clockwise 1/2 turn with a flat head screwdriver and prying out.





14

Replace uppermost factory screw removed in step 9 at top of bumper cover.



15

Using a 5/16" bit, drill holes at indents located at ends of Front Main Flare and Front Bumper Pieces. 2 places each part.

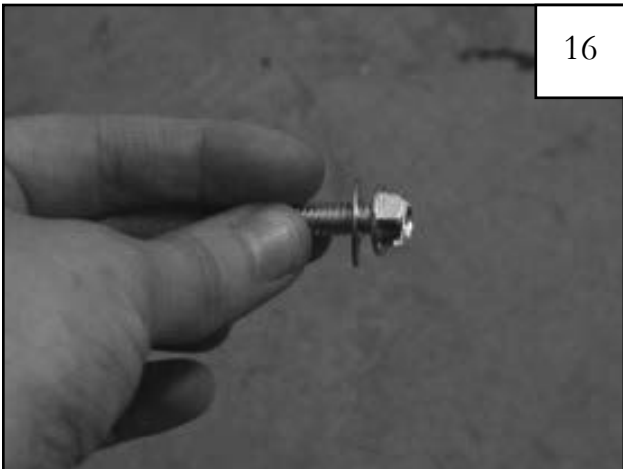

16

Slide a supplied Washer (WA1-0005) onto a supplied Bolt (SW1-0005).



17

Insert the Bolt/Washer assembly through the hole drilled in the end of the Front Main Flare in step 15 and into the corresponding hole drilled in the Front Bumper Piece. 2 places.

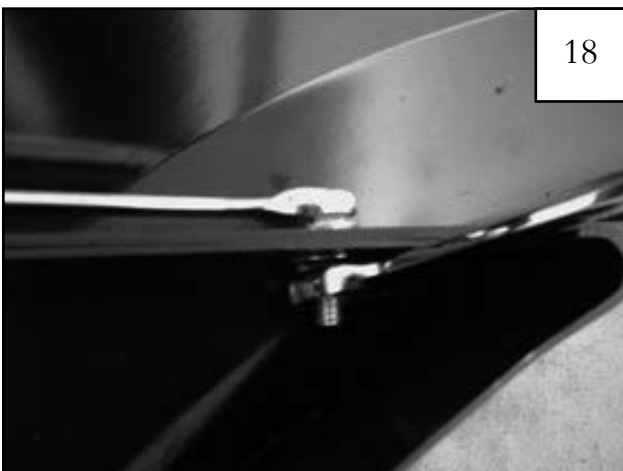

18

Install a supplied Nut (NU1-0011) on ends of Bolts (SW1-0005) and tighten.



19

Hold the flare firmly on the fender. Using a grease pencil, mark four clip locations using existing holes in flare. See step 20.

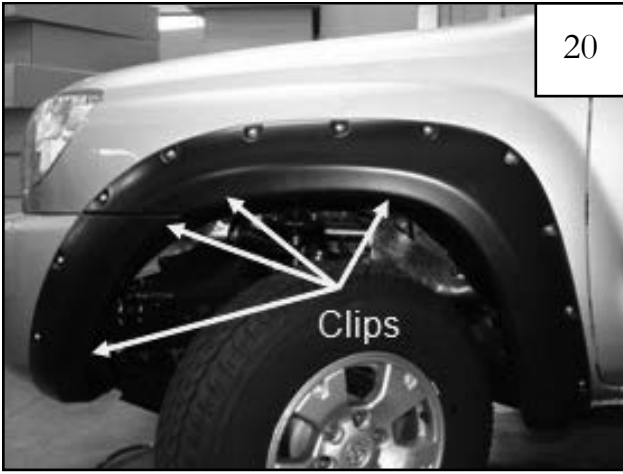

Clip locations.



Removed flare from fender. Stick a supplied Tab (MT1-0002) over marks made in step 19. 4 places.



Place a supplied Clip (CL1-0005) over each Tab. 4 places.

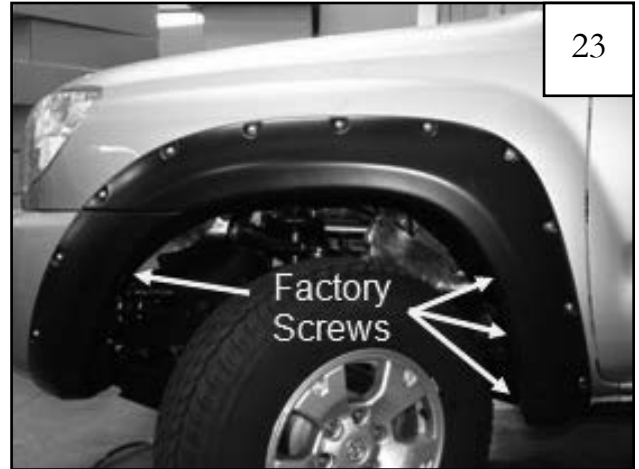

Reposition flare on fender and install four factory fasteners through holes in flare and into factory holes.



Install a supplied Screw (SW1-0050) through hole in flare and into Clip installed in step 22. 4 places.



Using a grease pencil, mark hole locations for Front Bumper Piece pockets. 2 places.

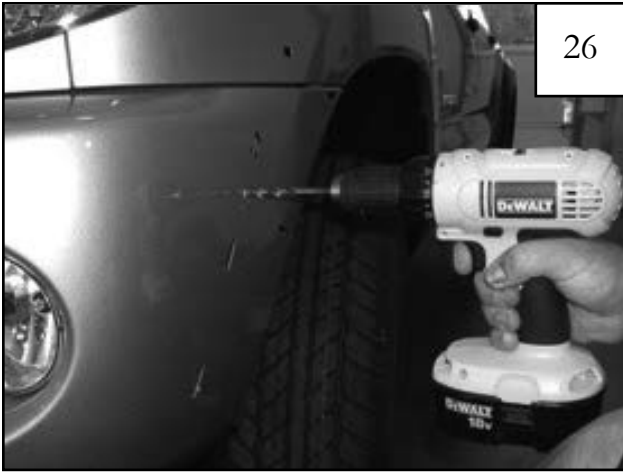

Remove fasteners installed in steps 23 - 24 and remove flare from fender. Drill at marked places with a 5/16" drill bit.

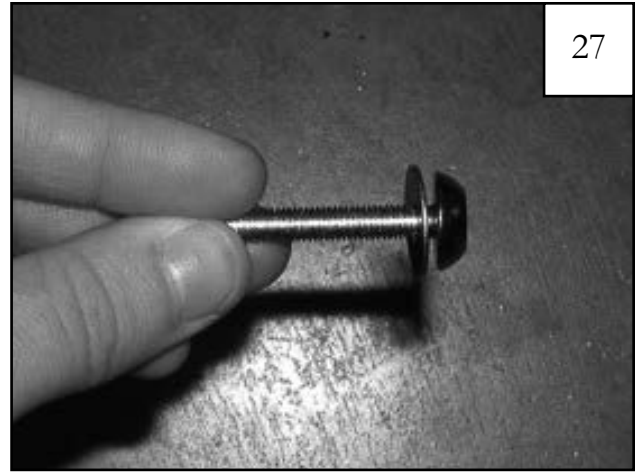

Slide a supplied Washer (WA1-0007) onto a Screw (SW1-0040).



Install Screw/Washer assembly through pocket holes of bumper piece. Place a supplied Spacer (SP1-0011) on the back of the Screw.



Situate flare on bumper, inserting screws through holes drilled in bumper in step 26.



Reinstall four factory screws through holes in flare and into factory holes.

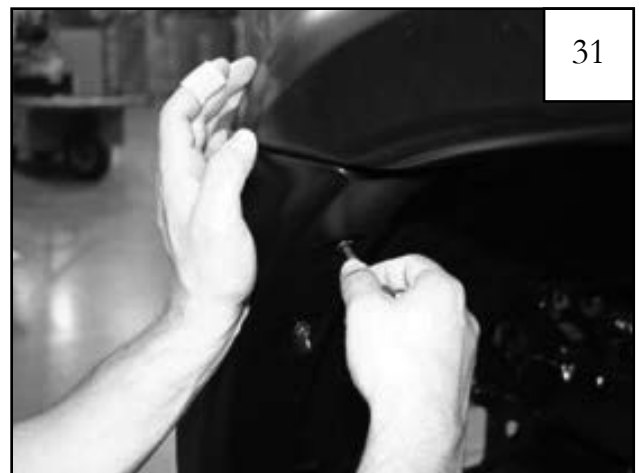

Reinstall four supplied Screws (SW1-0050) through holes in flare and into Clips.



32

Install a supplied Washer (WA1-0017) and a supplied Nut (NU1-0010) on back of screws installed in step 28-29. Tighten. *See Step 36 - 38 for Front Main Flare installation with Aftermarket Bumper.*

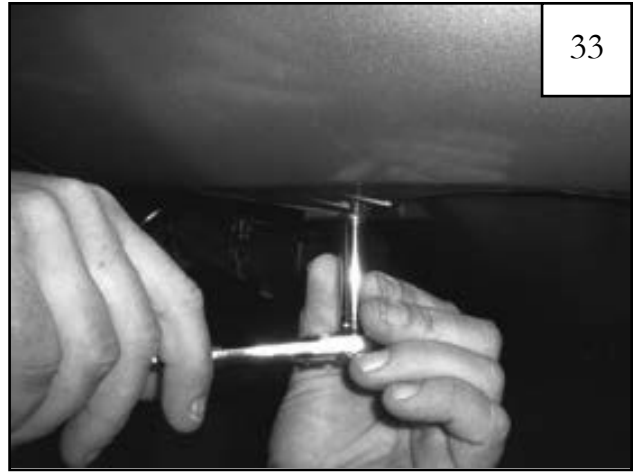

33

Pull down bumper cover and slide splash shield back in place. Replace factory screw in front of bumper cover to fasten splash shield to bumper cover.

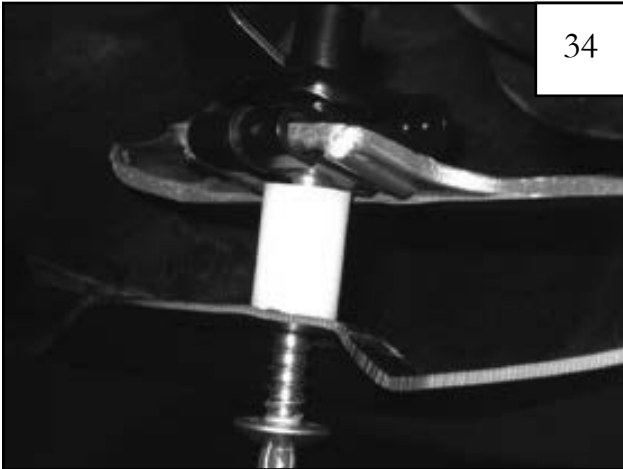

34

At bottom of Front Bumper Piece, install a supplied Screw (SW1-0034) through a supplied Spacer (SP1-0005) and into factory hole.



35

Completed front flare installation.



# Front Flare Installation Procedures With Aftermarket Bumper: (Driver's Side, No Front Bumper Piece)

*NOTE: Follow steps to install the front flares but disregard all steps to install the front bumper piece. The front bumper piece may be discarded. Variations on installation for the front flares are shown below.*



36

Slide a supplied Washer (WA1-0007) onto a supplied Screw (SW1-0040).



37

Install Screw/Washer assembly through foremost pocket hole in the Front Main Flare. Place a supplied Spacer (SP1-0011) on the back of the screw. Remaining pockets will use Screws (SW1-0032). Steps 2 - 3.



38

Pull back splash shield. Install a supplied Washer (WA1-0017) and a supplied 8 mm Serrated Flange Nut (NU1-0011) on back of screw. Tighten.

*NOTE: Install aftermarket bumper as suggested by manufacturer.*

# Rear Flare Installation Procedures (Driver's Side):

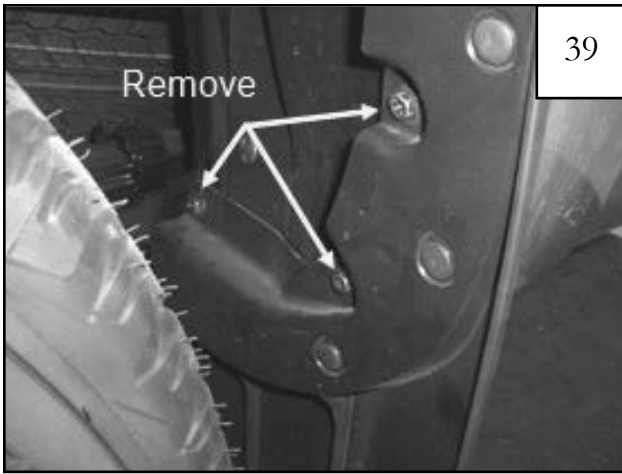

Remove three factory screws from mud flap. Save screws for reinstallation. Discard mud flap.

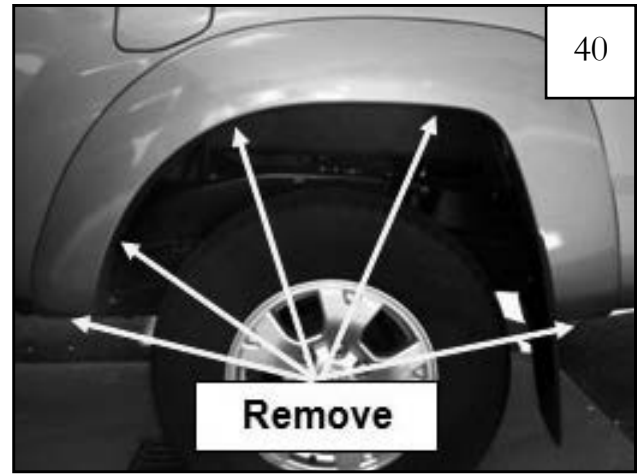

Remove five factory screws. Save screws for reinstallation. Remove flare by pulling part away from side of vehicle.

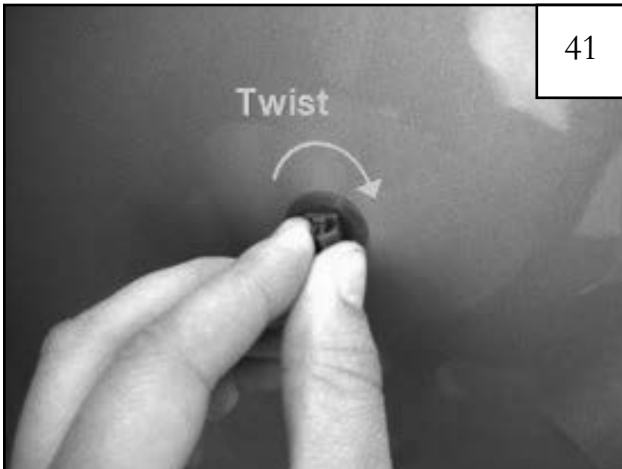

Using a clockwise twisting motion, remove eight factory plastic clips from fender. See step 43.

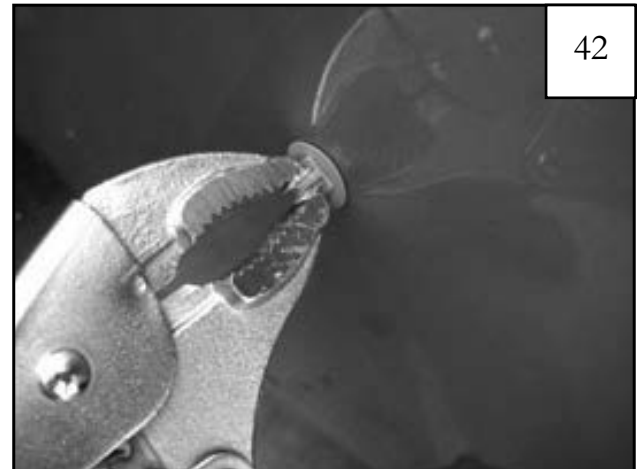

Remove three clips from fender using vise grips, pulling with a rocking motion. See step 43.

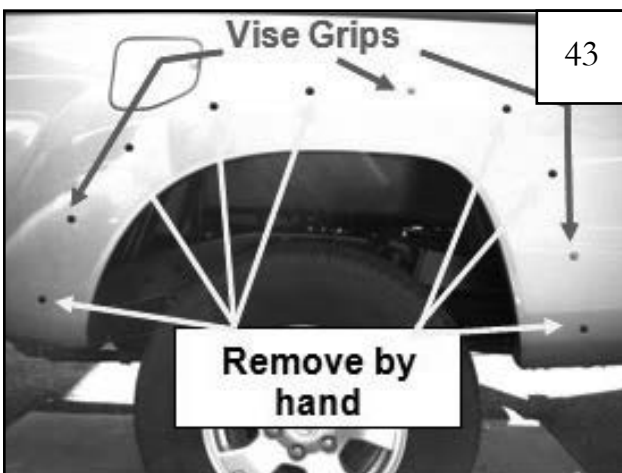

Clip locations.



Position flare on fender and install seven factory fasteners through holes in flare and into factory holes.

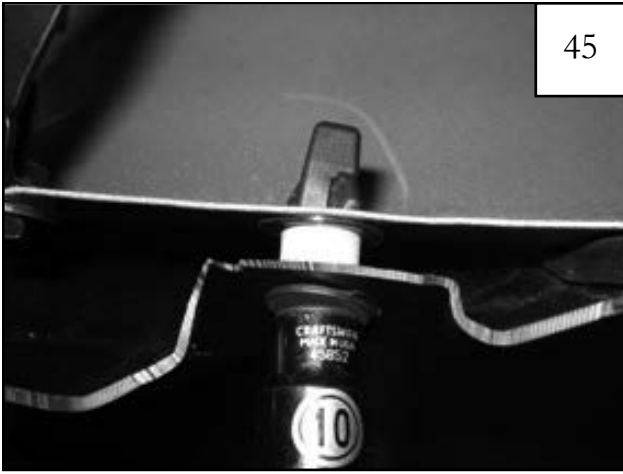

45

At bottom front of flare, install a supplied Screw (SW1-0036) and a Spacer (SP1-0003).

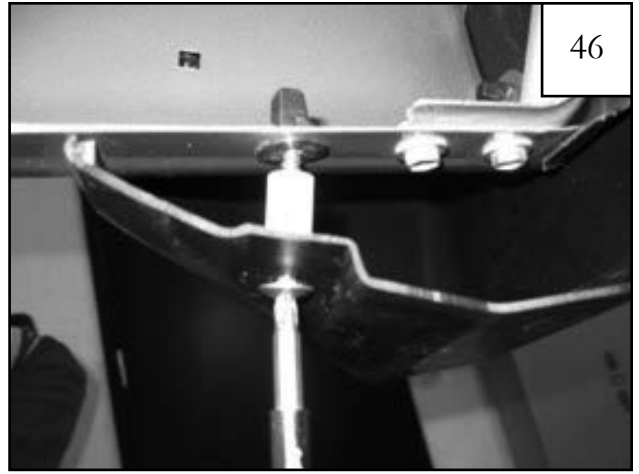

46

At bottom rear of flare, install a supplied Screw (SW1-0034) and a Spacer (SP1-0008).

## Edge Trim Tool Procedures:

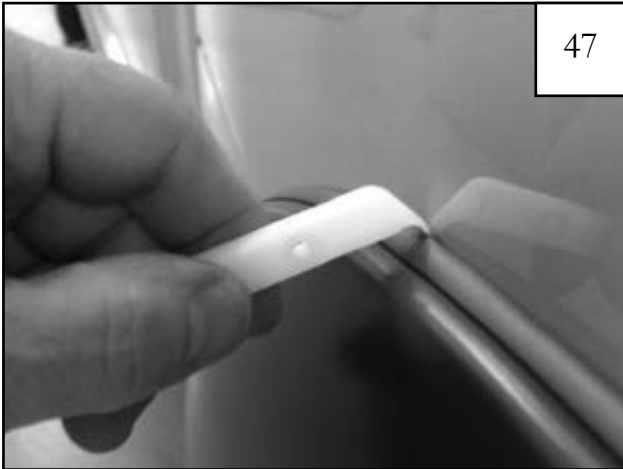

47

Using supplied Edge Trim Tool (ET1-0002), seat edge trim against vehicle by hooking curved end under edge trim at one end of flare. Next, slide around outer edge of flare to the other end.



48

Using flat end of supplied Edge Trim Tool (ET1-0002), seat edge trim against flare by inserting straight end between edge trim and flare at one end. Next, slide around entire edge to the other end.