



**INSTALLATION MANUAL**  
**MATRIX FRONT BUMPER**  
**PRODUCT NUMBER: X385X**  
**APPLICATION: 2014+ TOYOTA TUNDRA**



## **IMPORTANT SAFETY GUIDE** | Your safety and the safety of others is very important.

In order to help you make informed decisions about safety, we have provided the following warnings, safety precautions, installation instructions, and other important information to alert you to potential hazards that could hurt you or others.

Please do a job safety analysis before each task to identify potential hazards for your situation and remove/protect against them. Use own good judgment and take your time.

Check packaged materials immediately upon arrival to ensure that all listed parts are included and undamaged.

**Read and understand all warnings, safety precautions, and instructions before installing this product.**

**SENSORS FIELD OF VIEW MAY BE ALTERED WITH USE OF THE REPLACEMENT BUMPER.**

---

### **WARNINGS**

- Failure to observe the following warnings and instructions provided in this manual could lead to severe injury and/or death.
- For professional installation only. Careless installation and/or operation can result in serious injury, death, and/or equipment damage. All liability for installation and use rests with the user or consumer.
- Fab Fours, Inc. only approves installing this product according to these written instructions with the hardware provided. Failure to install according to these instructions will invalidate the warranty. This includes, but is not limited to, using alternative installation methods, hardware, or materials.
- This product is for off road use only.

---

### **SAFETY PRECAUTIONS**

- Always remove jewelry and wear eye protection.
- Always use extreme caution when jacking up a vehicle for work. Set emergency brake and use tire blocks. Locate and use the vehicle manufacturers designated lifting points. Use jack stands.
- Always use appropriate and adequate care in lifting components into place.
- Always ensure components will remain secure during installation and operation.
- Always wear safety glasses when installing this kit. A drilling operation will cause flying metal chips. Flying chips can cause serious eye injury.
- Always use extreme caution when drilling a vehicle. Always disconnect power before welding. Thoroughly inspect the area to be drilled (on both sides of material when possible) prior to drilling, and relocate any objects that may be damaged.
- Always use extreme caution when welding a vehicle. Thoroughly inspect the area to be welded (on both sides of material when possible) prior to welding, and relocate any objects that may be a fire hazard. When welding in a cab, make sure the interior surfaces are covered (e.g., welding blanket) and a fire extinguisher is at hand.
- Always use extreme caution when cutting and trimming during fitting.
- Always tighten all nuts and bolts securely per installation instructions.
- Always route electrical cables carefully. Avoid moving parts, components that become hot, and rough or sharp edges.
- Always insulate and protect all exposed wiring and electrical terminals.
- Perform regular inspections and maintenance on mounts and hardware.

# TABLE OF CONTENTS

- 2 SAFETY / DISCLAIMER
- 3 TABLE OF CONTENTS
- 4 A MESSAGE FROM THE OWNER
- 5 GETTING STARTED
- 6 PROVIDED MATERIAL
- 7 DISASSEMBLY
- 9 INSTALLATION
- 16 CONTACT

# A MESSAGE FROM THE OWNER

---



Fab Fours' was born out of a passion for customizing vehicles and a love of the outdoors. Our engineering team uses the latest 3D design software to turn new product ideas into reality. In our factory, designs come to life with the combination of cutting edge technology for metal cutting and forming and an American workforce that puts its' heart and pride into every product.

From design and manufacturing, to quality and delivery, Fab Fours' mission is to be the market leader for steel truck and jeep accessories. We make sure a quality product is delivered on time, more than expected, better than expected to our customers.

Enjoy your new Fab Fours product. Welcome to the family!

*Ereg Higgs*

**FOUNDER, FAB FOURS**

# GETTING STARTED

---

Before you begin the installation process of your new Fab Fours product, we suggest laying out all materials and parts on a pad or protective surface.

Failure to fully account for all components before beginning installation may leave vehicle immobile until part is acquired. Refer to the next pages as an inventory check.

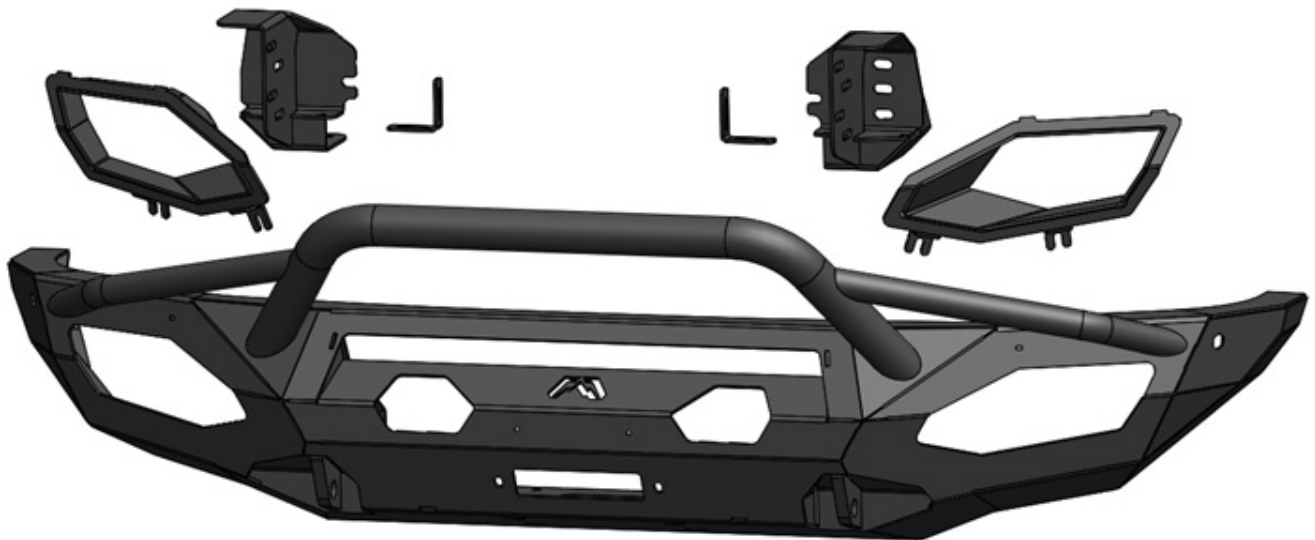

# PROVIDED MATERIALS



## HARDWARE KIT | 50201

| FAB FOURS IDENTIFICATION | COMPONENT DESCRIPTION                            | QTY |
|--------------------------|--|-----|
| 50201-HW                 | ½"-13, Yellow Zinc Hex Nut, Grade 8              | 8   |
| 50201-HW                 | 1/2", Yellow Zinc Flat Washer, Grade 8           | 8   |
| 50201-HW                 | 1/2", Yellow Zinc Lock Washer, Grade 8           | 8   |
| 50201-HW                 | 5/16"-18 x 1", Yellow Zinc Hex Cap Bolt, Grade 8 | 4   |
| 50201-HW                 | 5/16", Stainless Steel, Fender Washer            | 4   |
| 50201-HW                 | 5/16", Yellow Zinc Lock Washer, Grade 8          | 4   |
| 50201-HW                 | ¼"-20 x 1", Yellow Zinc Hex Cap Bolt, Grade 8    | 2   |
| 50201-HW                 | 1/4", Yellow Zinc Flat Washer, Grade 8           | 4   |
| 50201-HW                 | 1/4", Yellow Zinc Lock Washer, Grade 8           | 2   |
| 50201-HW                 | 1/4", Yellow Zinc Hex Nut, Grade 8               | 2   |

## TOOLS REQUIRED

- 10mm socket wrench
- 12mm socket wrench
- 14mm wrench
- 17mm socket wrench
- Pair of 7/16" wrenches
- 1/2" socket wrench
- 3/4" socket wrench
- Panel pry tool
- 5/16"-18 Tap and handle
- Zip ties
- Snips

## ASSISTANCE

We recommend two people perform the installation as items are heavy and may need to be held in place while installing.

## ORGANIZATION

Disassemble the vehicle where you can catalog and store everything. We suggest labeling and bagging all the OEM bolts when removing from the vehicle. Failure to keep track of parts could lead to an inability to properly reinstall components.

# DISASSEMBLY

*NOTE: Save all OEM parts until installation is complete!*

1. Using a 10mm socket wrench, remove the two (2) 10mm OEM bolts located in the wheel well securing the splash shield to the bumper cover. (Figure 1)

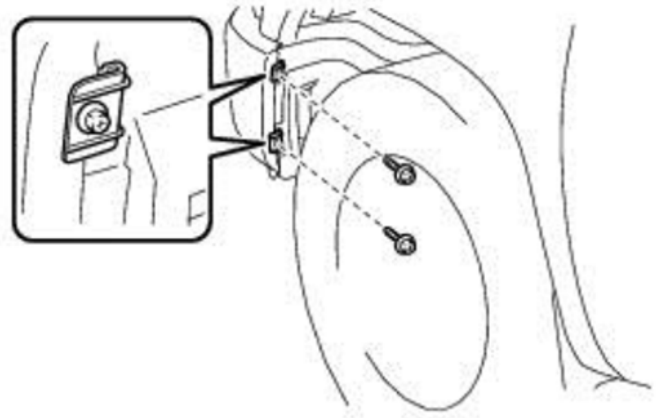

Figure 1

2. Using a 10mm wrench, remove the seven (7) OEM bolts under the bumper. (Figure 2, \*1 and \*2). Using a 12mm wrench, remove the four (4) OEM bolts under the bumper. (Figure 2, \*3)

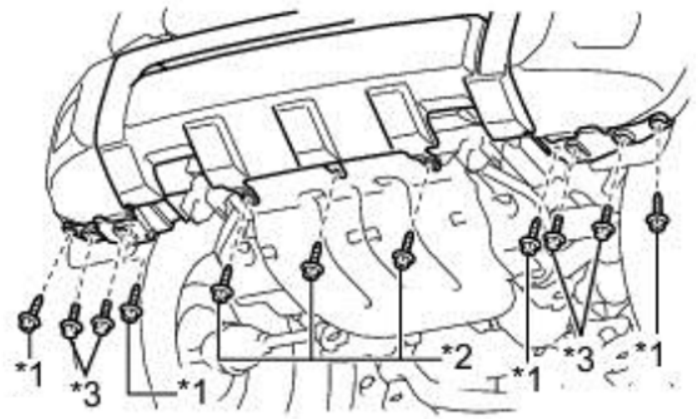

Figure 2

3. Reach inside the bumper through the wheel well and disconnect the fog light wiring harness from both sides. Disconnect the front sensor wiring harness from both sides if equipped.

4. Using a 17mm socket wrench, remove the four (4) OEM bolts securing the tow hooks to the bottom of the frame rail. (Figure 3)

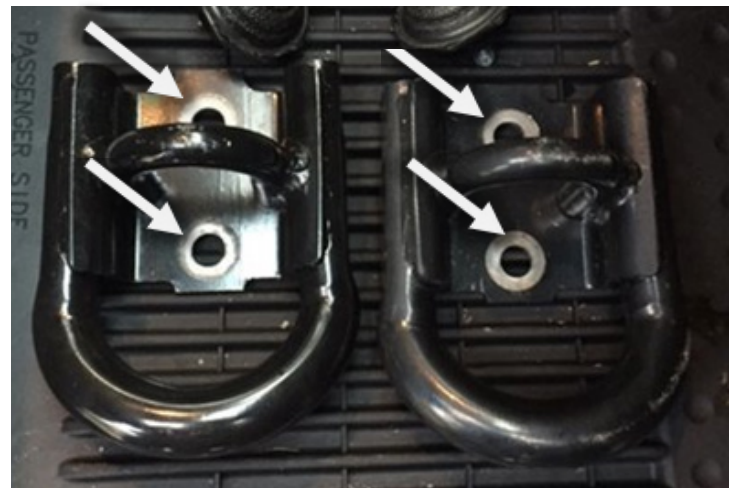

Figure 3

---

5. Using a 14mm wrench, remove the eight (8) nuts securing the bumper and crash bar to the frame rail end. (Figure 4)

6. Remove the front bumper from the vehicle.

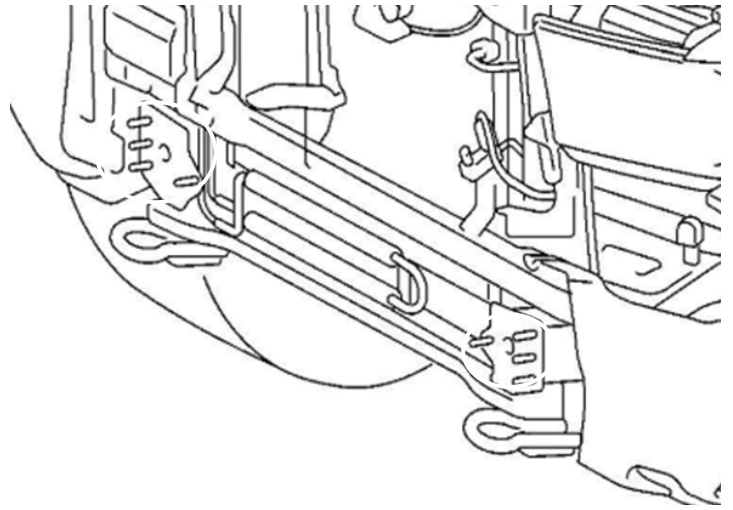

Figure 4

7. Remove both parking assist sensors from the bumper by pulling the white clip away from the black sensor. (Figure 5)

8. Rotate the sensor out of the sensor hole in the bumper.

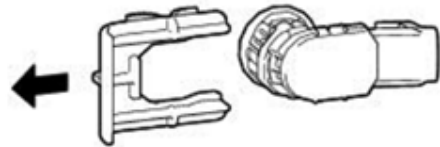

Figure 5



# INSTALLATION

*NOTE: Two (2) sensors, two (2) sensor wiring harnesses, two (2) sensor clips will be reused in the Fab Fours bumper if equipped. (Figure 5)*

*NOTE: It is always recommended to chase all projection nuts with their appropriate taps to clear out any foreign debris or powder coat. (Figure 6)*

**9. Using a ½" socket wrench and the provided 5/16" X 1.00" yellow zinc hex bolt, yellow zinc lock washer, and stainless-steel fender washer (50201-HW), fully install both light boxes (22015 & 22016) assemblies into the bumper (22014). (Figure 7)**

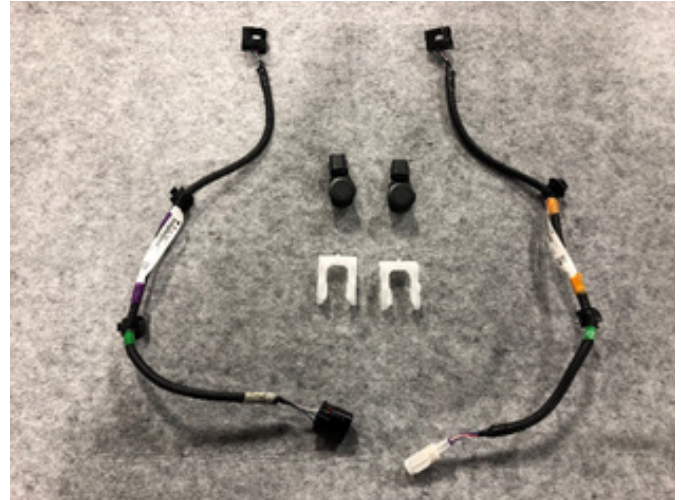

Figure 5



Figure 6



Figure 7

---

**10. Using a pair of snips, trim both OEM sensor clips in the manner shown. (Figure 8 – 9)**

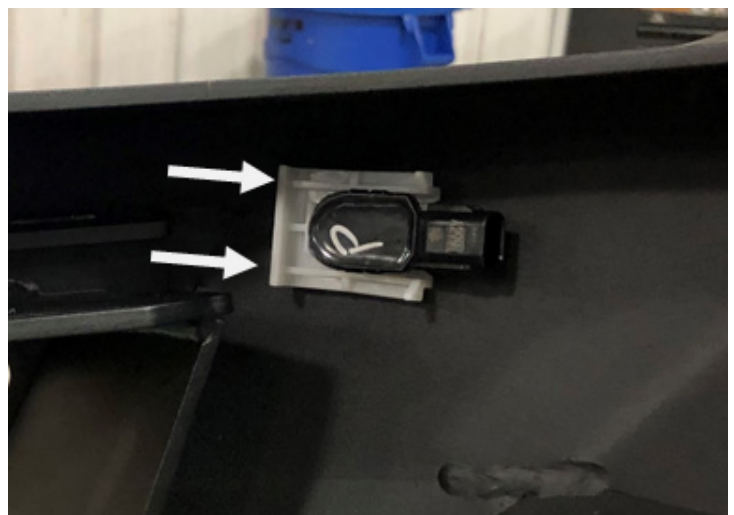

*Figure 8*



*Figure 9*

**11. Install both sensors into the bumper in the opposite manner as removed from the OEM bumper. (Figure 10.)**



*Figure 10*

**12. Install both sensor wiring harnesses onto the installed sensors. (Figure 11)**



*Figure 11*

**13. Insert the provided four (4) ½"-13 bolt strips (20296) into the winch tray pointing the bolts towards the wing of the bumper (22014). (Figure 12)**

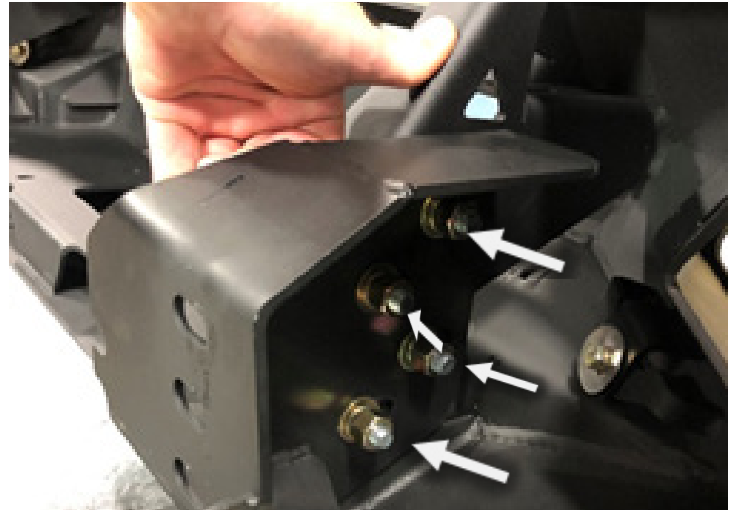

*Figure 12*

---

**14. Using the provided ½"-13 yellow zinc flat washers, yellow zinc lock washers, and yellow zinc hex nut, loosely install the bracket to the outside of the winch tray. (Figure 13)**

**Note: Hand tightening the brackets at the top of the adjustment slots helps when setting the bumper up onto the frame rail ends without fighting the factory valance.**



*Figure 13*

**Note:** Steps 15 thru 18 are only used if your installing a 30" light bar and/or winch.

**15.** Using the included "L" brackets (21871) and the two (2) ¼"-20 hex bolts, four (4) ¼" flat washers, two (2) ¼" lock washers, and two (2) ¼"-20 hex nuts (50201-HW), loosely install the "L" brackets to the inside of the bumper (22014) hand tight.

**16.** Using the factory hardware for the 30" light bar, securely tighten the light bar to the "L" brackets following the manufactures steps and recommended tools.

**17.** Using a pair of 7/16" wrenches, center the light bar and fully tighten the two (2) ¼"-20 bolt stacks. (Figure 14)



*Figure 14*

**18.** If applicable, fully install your winch into the bumper at this time while following the manufactures instructions and using the recommended tools and hardware.

**19.** With assistance lift and set the bumper assembly up onto the frame rail studs.

---

**20. Hand tighten the four (4) tow hook bolts through the brackets (22015 & 22016) and into the frame. (Figure 15)**



*Figure 15*

**21. Hand tighten the eight (8) OEM bolts securing the brackets (22015 & 22016) to the end of the frame rail. (Figure 16 & 17)**

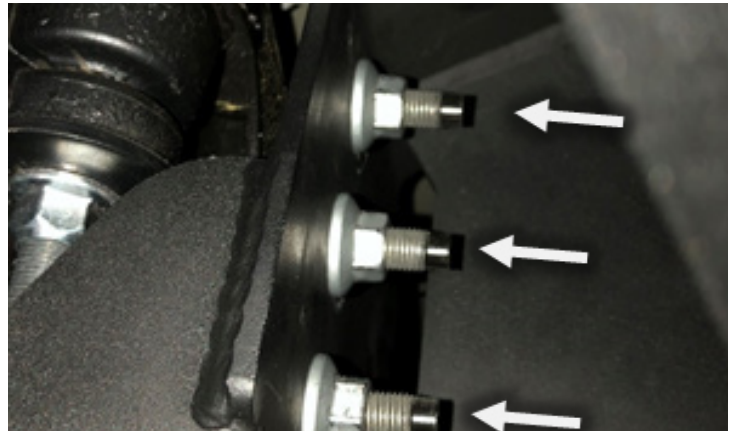

*Figure 16*



*Figure 17*

---

**22. While stabilizing the bumper (22014), center the bumper between both valances.**

**23. Using both a 14mm and 17mm socket wrench, fully tighten the four (4) tow hook bolts and eight (8) frame rail end bolts.**

**24. With assistance, lift and align the bumper (22014) to the center grill and valance**

**25. Using a  $\frac{3}{4}$ " socket wrench, fully tighten down the eight (8)  $\frac{1}{2}$ "-13 yellow zinc hex nuts. (Figure 18)**



*Figure 18*